

# GB2620PT

## HYDRAULIC INSTALLATION TOOL

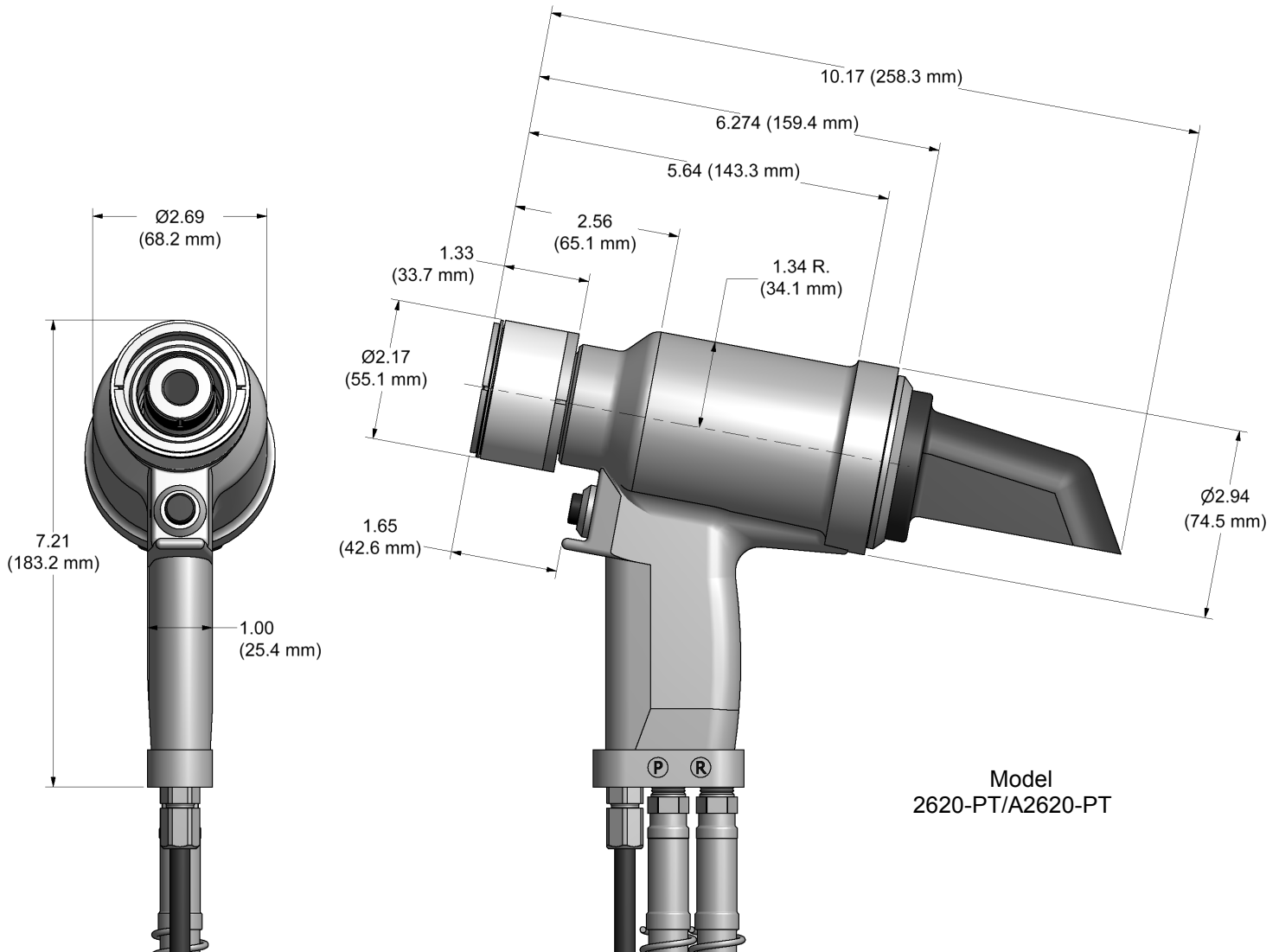

### DESCRIPTION

The GB2620PT is a hydraulic installation tool capable of installing 1/2" lockbolts. It weighs 9 lbs. 14 oz (4.5 kg). It has a 1.437" (36.5mm) rivet setting stroke and a rated pull load of 17,745 lbs (78.9 kN) @ 6,500 psi. (448.2 bar).

The GB2620PT (Electric actuated) installation tool operates on hydraulic pressure developed by the GB940 powerunit set at 7,400 psi. (510.2 bar) maximum PULL pressure and 3,200 psi. (220.6 bar) maximum RETURN pressure, enabling the tool to pull all the fasteners listed on the selection chart without adjusting pressures. Powerunit may be set to the pressures only needed to pull your specific fastener using the pressure gage assy (942280). The tool comes equipped with 2 feet (.61 m) of hoses and electric cord kit complete with quick disconnects.

**NOSE ASSEMBLIES ARE NOT FURNISHED WITH THE TOOL AND MUST BE ORDERED SEPARATELY.**



# ACCESSORIES



## GB2620PT SELECTION CHART

**Split Ring Group  
#504124**  
*Required to attach to tool  
(Sold Separately)*

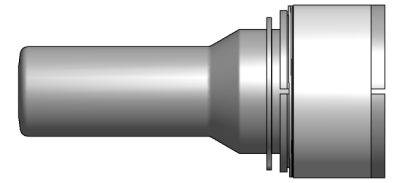

FASTENER	DIA.	NOSE ASSEMBLY
LOCKBOLT HIGH TENSILE PULL TYPE C50L® LD AVDELOK®	1/2"	16-2620PT-41
BOM® AVBOLT®	3/8" 1/2"	BOM12-2620PT-31 <sub>1</sub> BOM16-2620PT-41
HP8	1/2"	CONTACT GAGE BILT FOR YOUR REQUIREMENTS
HP10.9	12mm	CONTACT GAGE BILT FOR YOUR REQUIREMENTS

C50L® AND BOM® ARE REGISTERED TRADEMARKS OF ARCONIC INC. AVDELOK® AND AVBOLT® ARE REGISTERED TRADEMARKS OF AVDEL UK LIMITED.

1. 504124 SPLIT RING GROUP REQUIRED TO ATTACH TO TOOL (SOLD SEPARAETLY)

### GAGE BILT CERTIFIES THE GB2620PT WILL INSTALL THE ABOVE FASTENERS

NOTE: THE LAST 2 DIGITS OF THE NOSE ASSEMBLY REPRESENTS THE LENGTH THE NOSE ASSEMBLY EXTENDS FROM THE TOOL. (I.e. -41 = 4.1 inches)

REV. 9/17

### WARRANTY

Seller warrants that all goods covered by this catalog will conform to applicable specifications and will replace or repair, EXW our plant, any goods providing defective from faulty workmanship, or material, for 1 year from date of shipment.

Said warranty to remain in effect if, and only if, such goods are used in accordance with all instructions as to maintenance, operation and use, set forth in manuals and instruction sheets furnished by seller.

Sellers obligation under this warranty shall be limited to the repair or rework of the goods supplied or replacement thereof, at Seller's option, and in no case is to exceed the invoice value of said goods. Under no circumstances will the seller be liable for incidental or consequential damages or for damages incurred by the buyer or subsequent user in repairing or replacing defective goods or if the goods covered by this warranty are reworked or subjected to any type of additional processing.

This warranty is void if Seller is not notified in writing of any rejections or defects within 1 year after the receipt of the material by the customer.

**THIS WARRANTY IS MADE IN LIEU OF ALL OTHER WARRANTIES EXPRESSED OR IMPLIED, INCLUDING MERCHANTABILITY.**